

On slender shells and related problems suggested by Torroja's structures

J.I. Díaz

Departamento de Matemática Aplicada, UCM

Jornada sobre Teoría de la Elasticidad

E. T. S. I. Caminos, Canales y Puertos, May, 22, 2006

1. Introduction

The experience shows that when considering a slender or shell a small curvature in the transversal direction to the main length supply an extra rigidification with respect to the planar case:

* flexible steel retractable meter tape measure, ...,

We shall carry out the study of the asymptotic modelling of such kind of shell structures

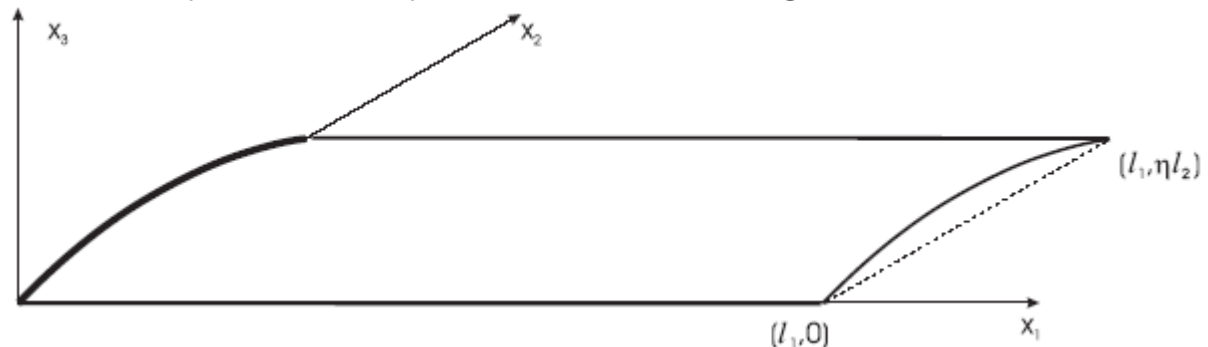

We also will consider more sophisticated structures formed by coupling two of such basic shells by means of an edge with slight folding

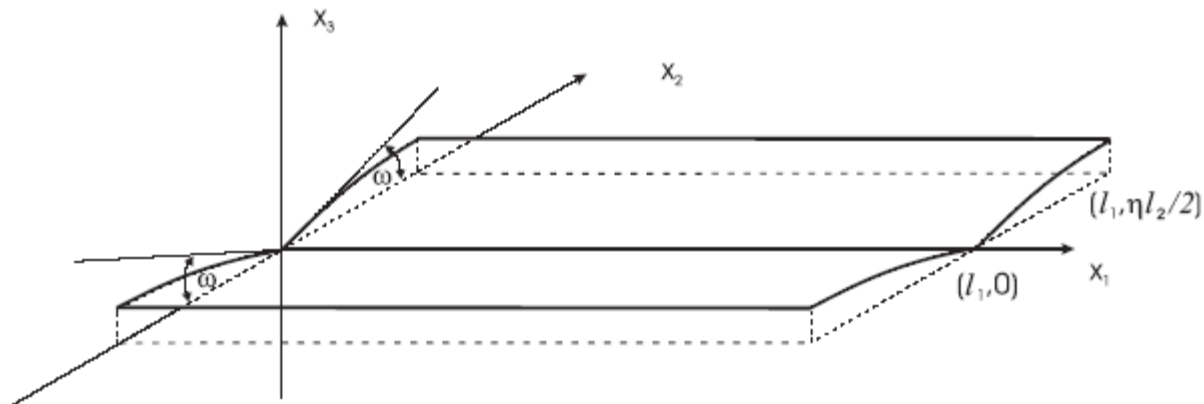

as well as the case of an infinity set of shells obtained by the periodic repetition of the basic structure

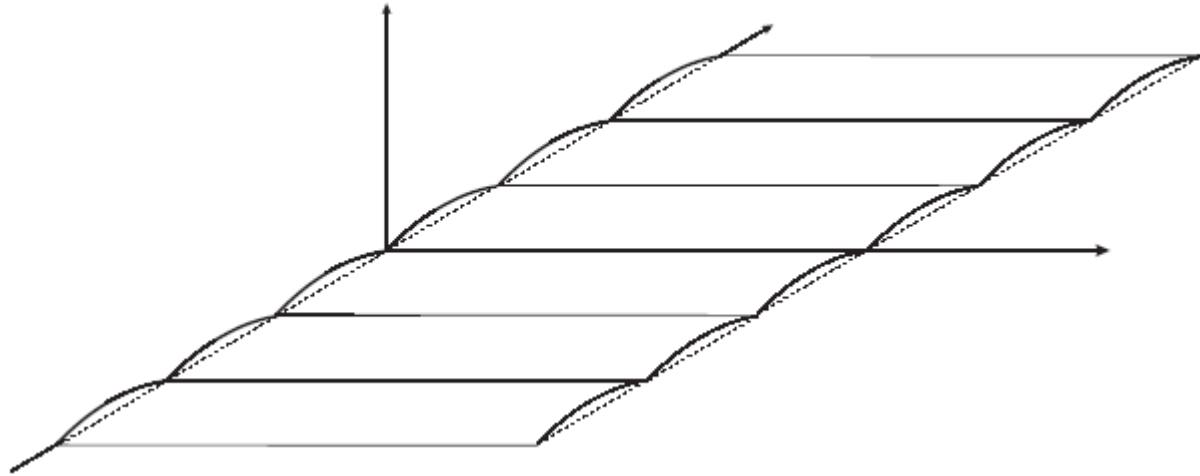

The consideration of this type of periodic structures is motivated by some of the structures designed by the outstanding engineer Eduardo Torroja (Madrid, 1899-1961).



Foto: M. García Moya.

For instance, the shell roofs of the Madrid Racecourse (1935) are a brilliant result of the forms of the reinforced concrete consisting of a system of portal frames, spread at 5 m intervals and connected longitudinally by small reinforced concrete double curvature vaults.

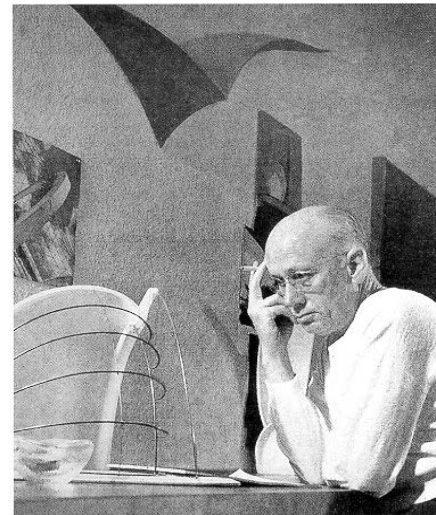
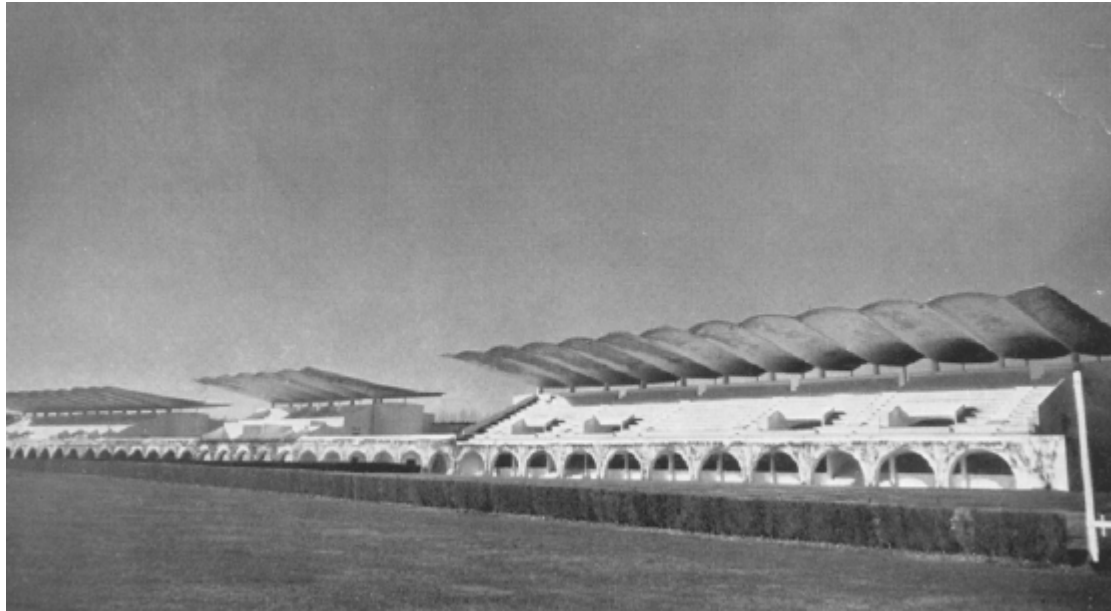

HIPÓDROMO DE LA ZARZUELA. MADRID, 1935.

C. Arniches, L. Domínguez y Eduardo Torroja. Con la empresa constructora Agroman E.C.

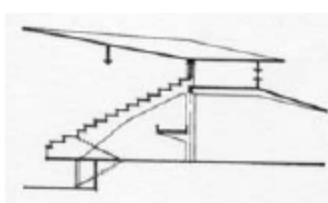
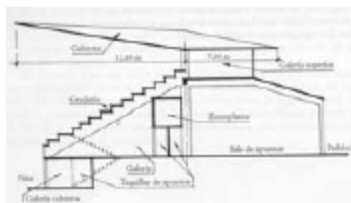

PRIMERA REVISION

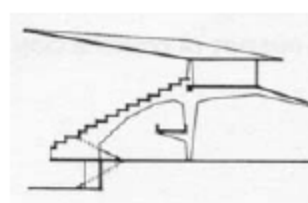

SEGUNDA REVISION

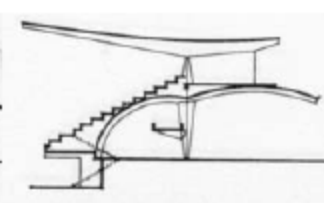

REVISION FINAL

5 m intervals and connected longitudinally by small reinforced concrete double curvature vaults. The cantilever roof, with a minimum thickness of 5 cm, overhangs to a distance of 12,8 m.

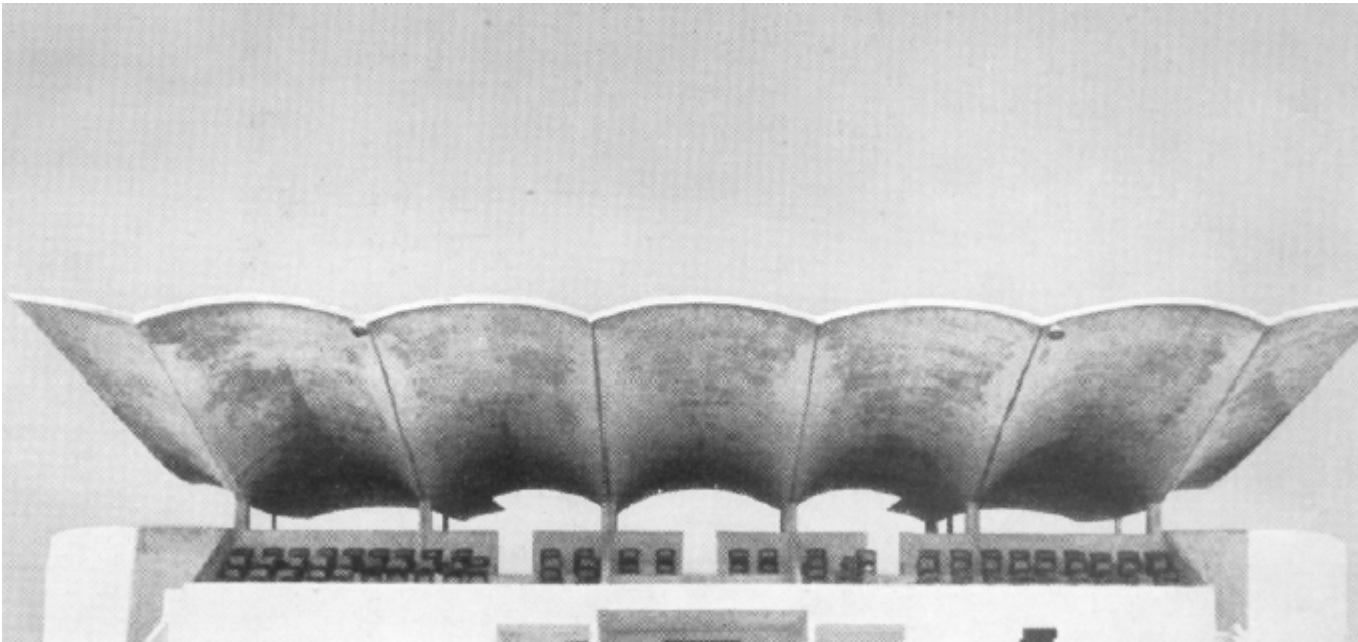
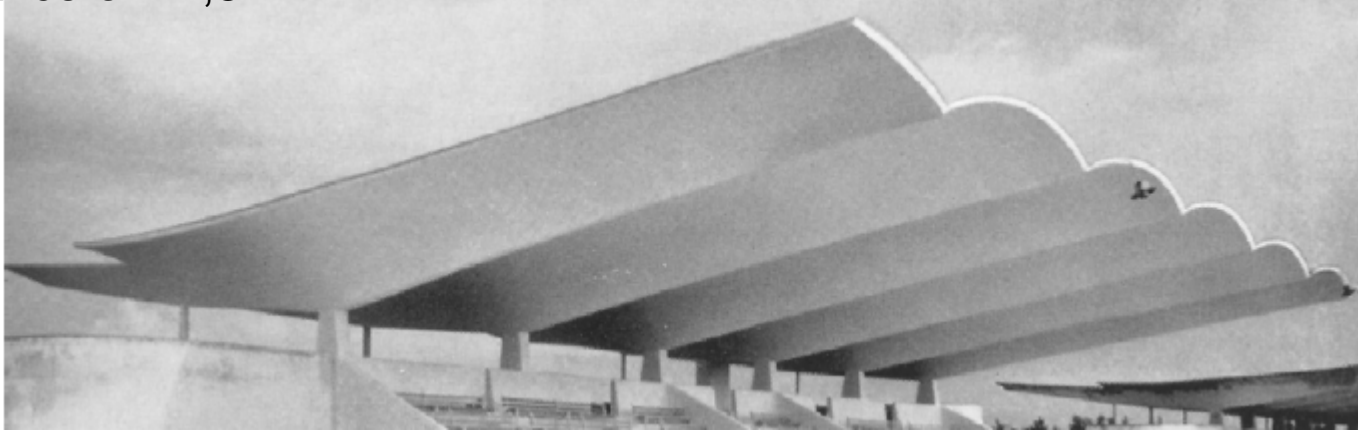

Although Torroja also produced many theoretical works (...) the mentioned structure was “calculated” (??) so as to find out the directions and strengths of the stresses that would occur.

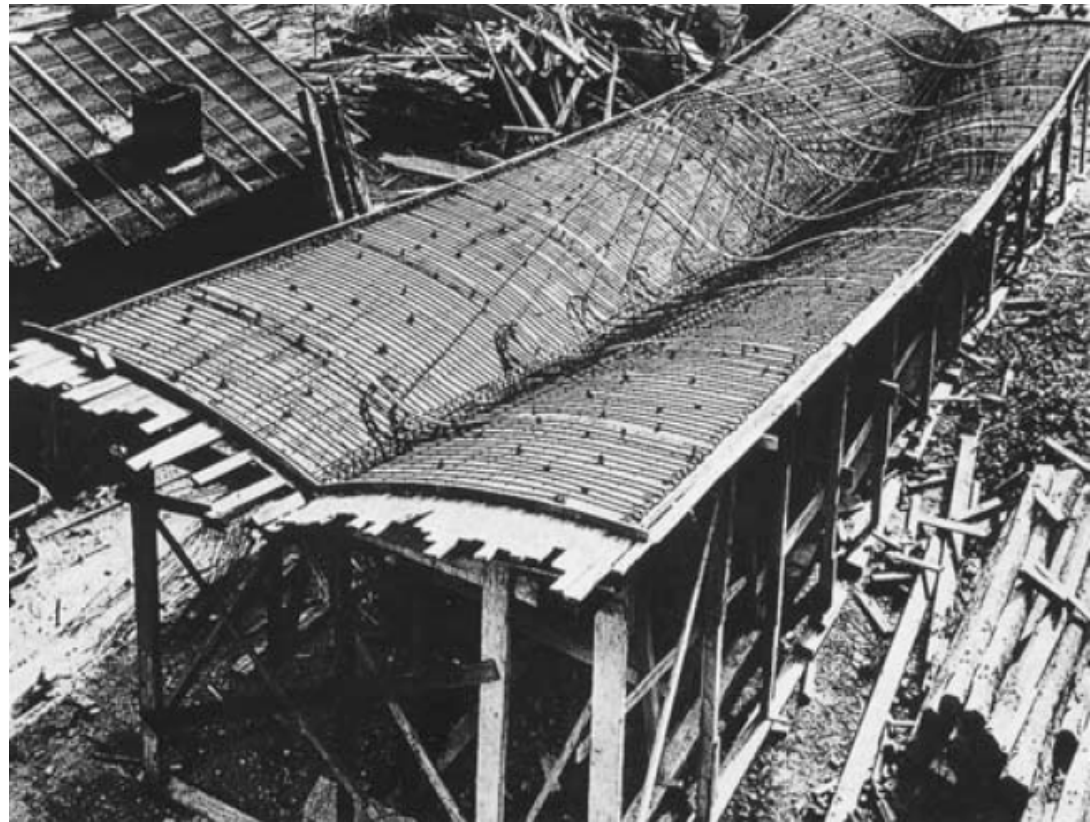
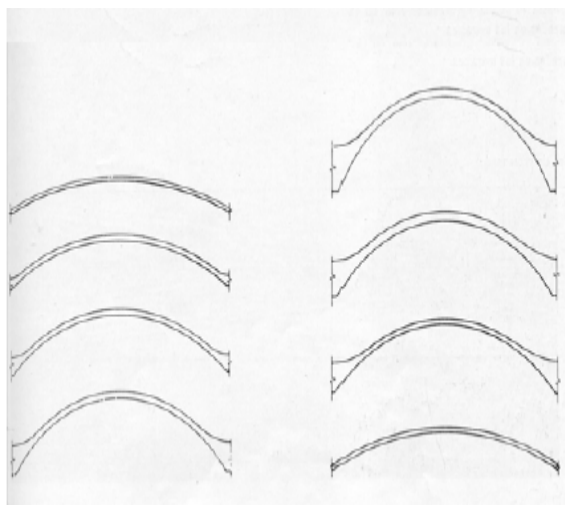
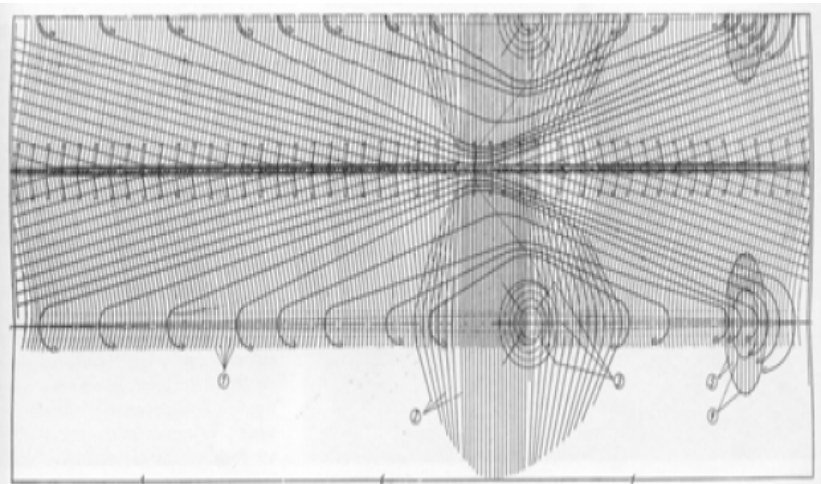

Later on, tests were carried out on a full scale module of the roof (quite similar to the coupled shell considered here in Figure 2) and it was loaded to breaking point.

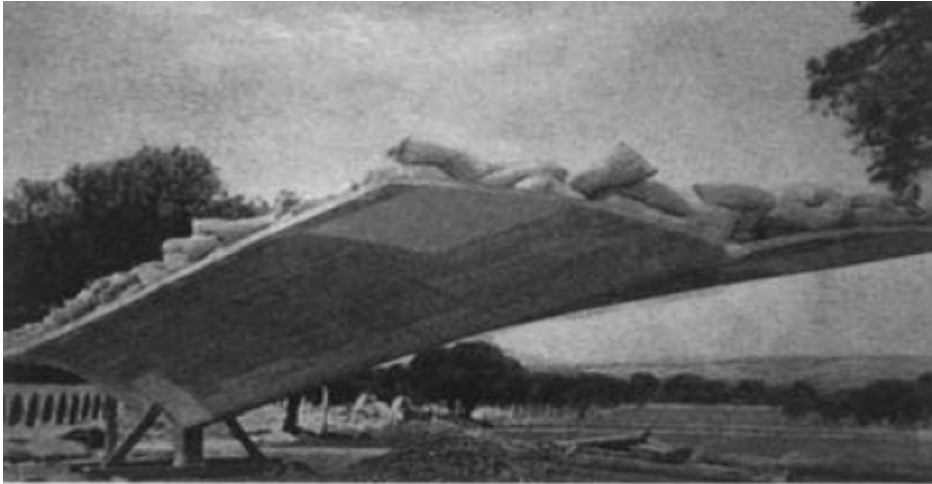

In fact, in his book, E. Torroja, *The Structures of Eduardo Torroja*, F. W. Dodge Corporation, New York, 1958 (Ministerio de Fomento, Madrid, 1999) he writes (p. 12):

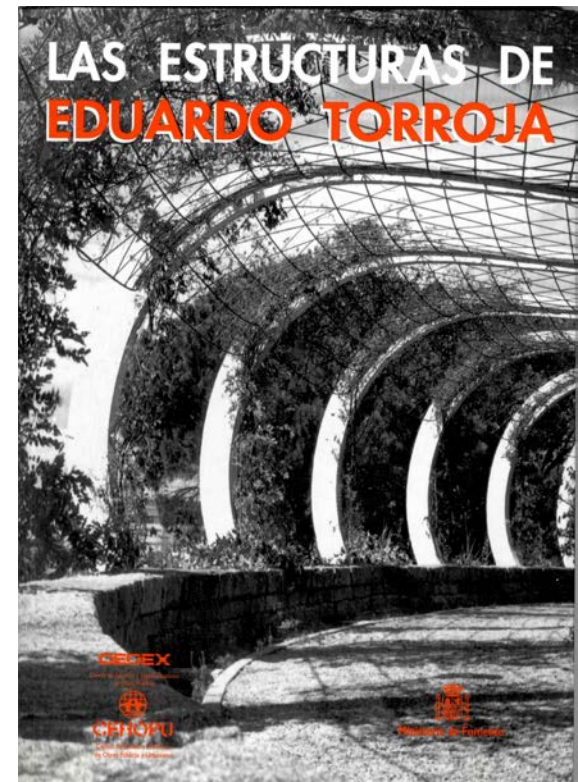

La teoría de la elasticidad no ha desarrollado aún procesos matemáticos adecuados para el análisis de esfuerzos en una estructura de este tipo, pero a pesar de ello y aunque no se cuenta con un análisis de gran precisión, se sabe que poseen buenas propiedades estructurales en el espacio. Para el edificio que nos ocupa, se realizaron varias pruebas con el único propósito de estimar la dirección e intensidad de los esfuerzos más probables (véase el diagrama anterior).

The present talk, based on my joint paper with

E. Sanchez-Palencia,



*Laboratoire de Modélisation en Mécanique, Université Pierre et Marie Curie,
and Academie des Sciences,*

try to carry out a mathematical study of such type structures which, with difficulty, would be available in the first half of the last century.

Another example is the "pedestrian access shell in the southwestern side of the UNESCO building (Paris, 1953-58) due to Marcel Breuer and Bernard Zehrufuss with the collaboration of Antonio and Pier Luigi Nervi

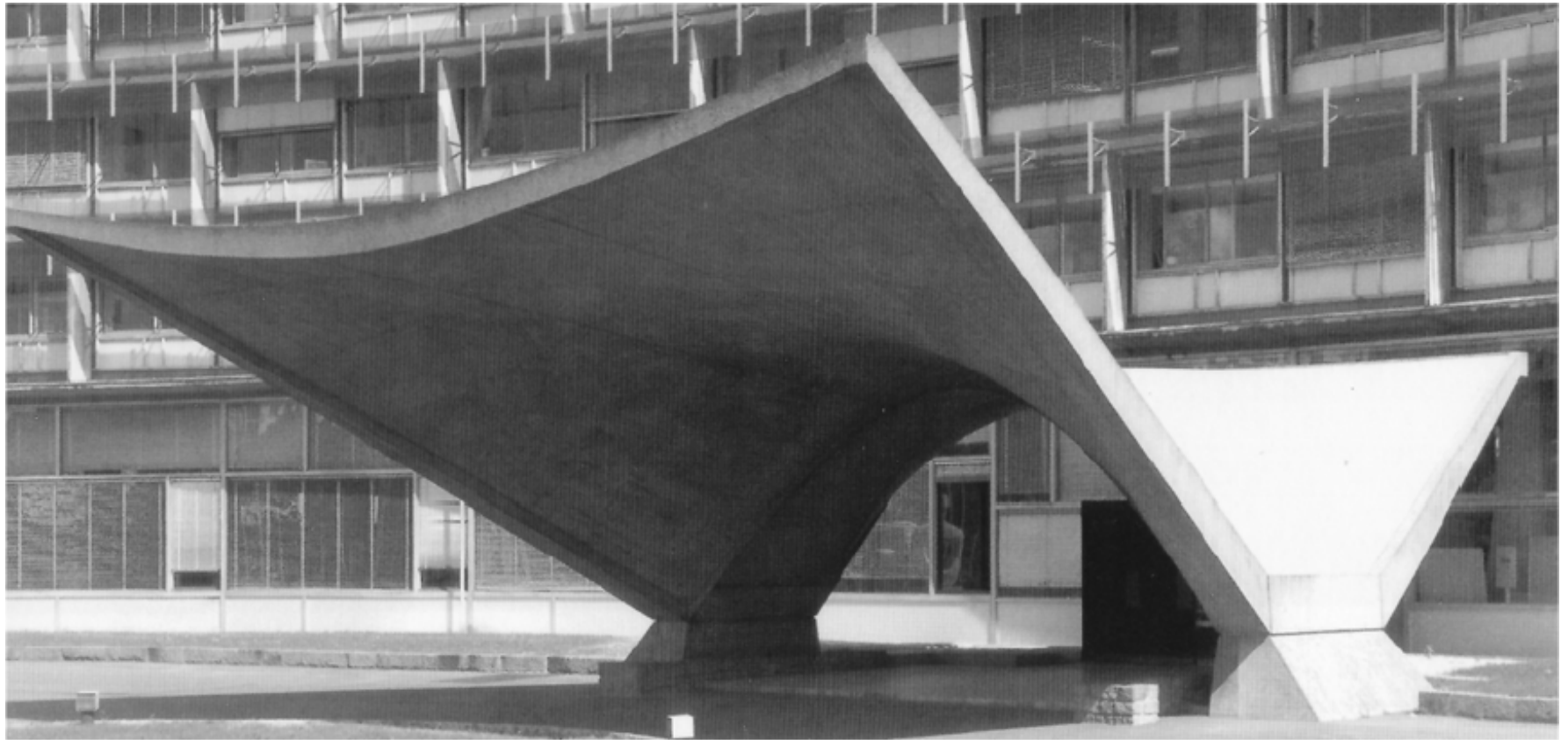

2. The basic problem.

We consider a slender cylindrical shell

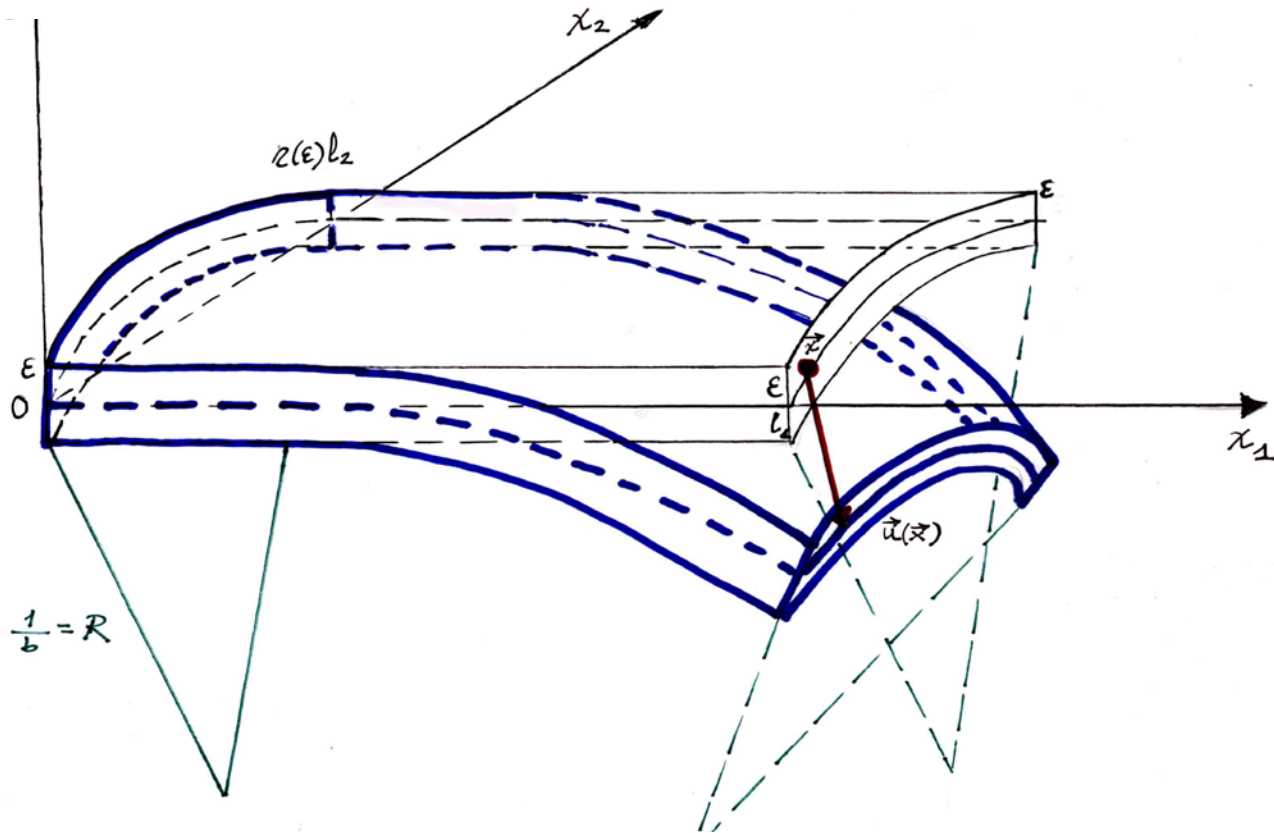

According to standard notations in cylindrical shell theory the “plane of parameters x_1, x_2 ” is merely the middle surface (cylinder) of the shell developed into a plane. We chose x_1 in the direction of the generators and x_2 normal to them, so that the principal curvatures are zero in the direction x_1 and $b = 1/R$ in the direction x_2 , where R denotes the radius of the cross section

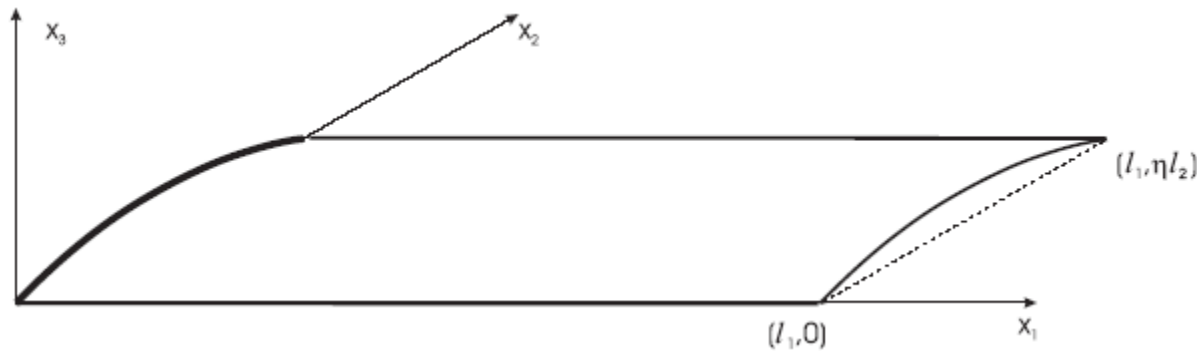

Accordingly, the second fundamental form of the surface has components $b_{11} = b_{12} = 0$ and $b_{22} = b$, Moreover, the Christoffel symbols of the surface vanish identically, so that covariant and classical differentiation coincide. Since $b_{12}^2 - b_{11}b_{22} = 0$ the surface is parabolic, i.e. the directions of the principal curvatures coincide

Remark *As a matter of fact, the Torroja's structure mentioned at the introduction was not composed by cylindrical elements but by slightly hyperbolic ones. Nevertheless, the curvature in the longitudinal direction was much smaller (and even it vanished in early projects by Torroja: see [36] Chapter 1) than in the transversal direction, so that our model with zero longitudinal curvature may be considered as a first approximation.*

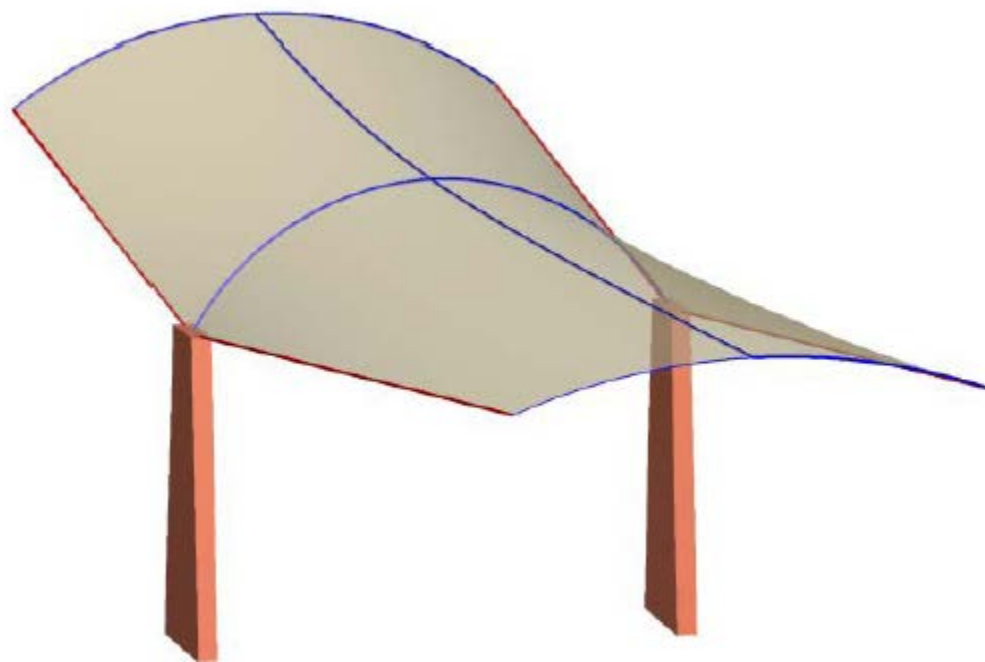
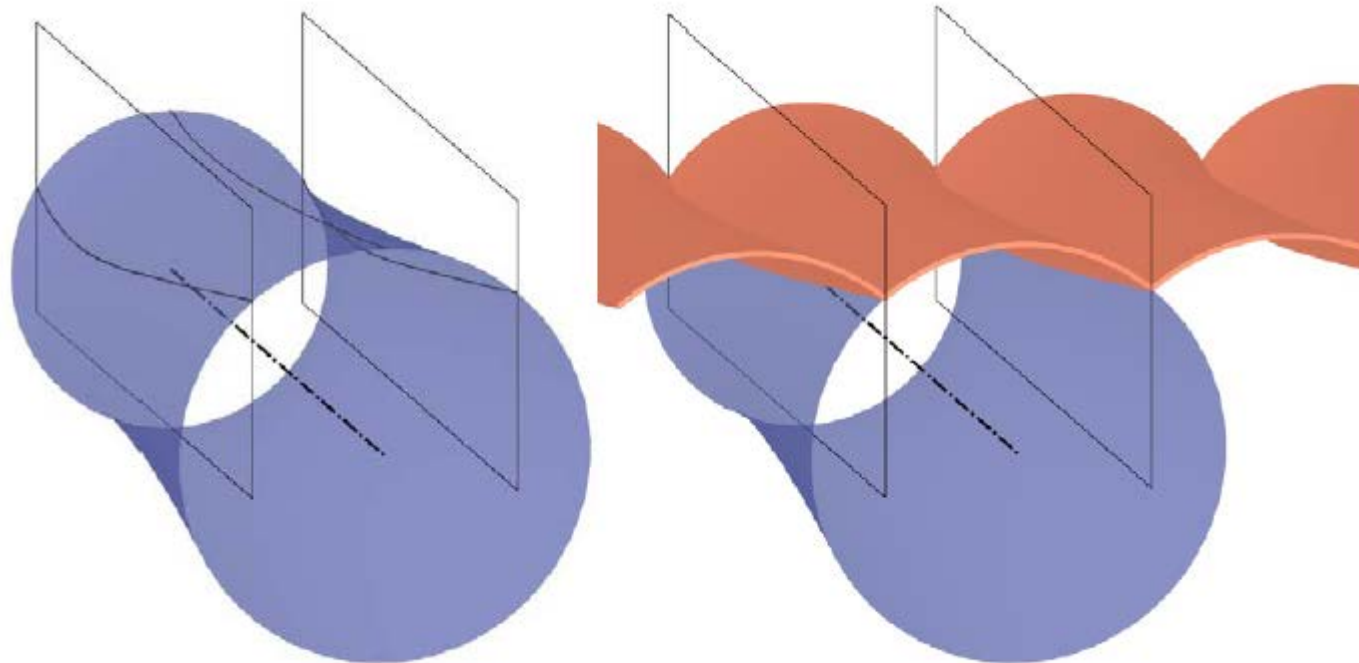

Let ε be a small parameter, the relative thickness of the plate. Let $\eta = \eta(\varepsilon)$ be a new small parameter satisfying

$$\varepsilon^{1/3} \leq \eta \leq 1.$$

the typical example will be $\eta = \varepsilon^{1/4}$. Let us denote the shell domain by $\Omega_\varepsilon = (0, l_1) \times (0, \eta l_2)$,

$$\text{with } \eta l_2 \leq 2R.$$

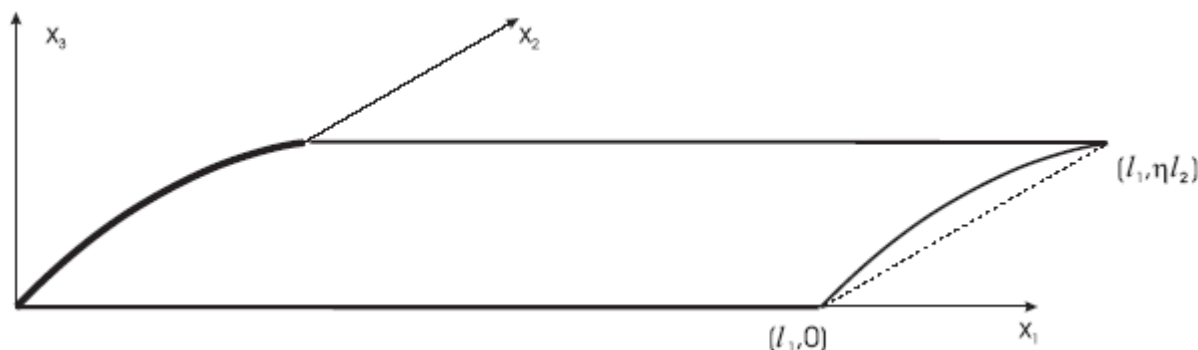

The corresponding tangential displacements are \tilde{u}_1, \tilde{u}_2 , whereas \tilde{u}_3 is the displacement normal to the shell. Some times we shall use the notation $\tilde{\mathbf{u}} = \tilde{\mathbf{u}}^\varepsilon$ to indicate explicitly the ε -dependence.

We shall admit, in this section, that the shell is clamped by the “small curved boundary” $(\{0\} \times [0, \eta l_2])$ and free by the rest. This implies the kinematic boundary conditions:

$$0 = \tilde{u}_1 = \tilde{u}_2 = \tilde{u}_3 = \tilde{\partial}_1 \tilde{u}_3 \quad \text{on } \{0\} \times [0, \eta l_2],$$

where

$$\tilde{\partial}_\alpha = \frac{\partial}{\partial x_\alpha}.$$

The space of configuration will be denoted by V_ε . It is the subspace of $H^1(\Omega_\varepsilon) \times H^1(\Omega_\varepsilon) \times H^2(\Omega_\varepsilon)$ formed by the functions satisfying the kinematic boundary conditions

Although it is possible to write the complete system of equations modeling the above elastic problem (the “strong formulation”: see. e.g.

F. Niordson, *Shell theory*, North Holland, Amsterdam, 1985

here we shall follow a “variational or weak formulation”

$$\varepsilon a(\mathbf{u}^\varepsilon, \mathbf{v}) + \varepsilon^3 b(\mathbf{u}^\varepsilon, \mathbf{v}) = \langle \mathbf{f}, \mathbf{v} \rangle$$

where the coefficients ε and ε^3 account for the fact that the membrane and flexion rigidities are proportional to the thickness of the plate and to its cube, respectively. Moreover, the two bilinear forms $a(\mathbf{u}^\varepsilon, \mathbf{v})$ and $b(\mathbf{u}^\varepsilon, \mathbf{v})$ on the space \mathbf{V} are defined through the previous expressions (membrane strains in shell theory):

$$\tilde{T}^{\alpha\beta}(\tilde{\mathbf{u}}) = \tilde{T}^{\beta\alpha}(\tilde{\mathbf{u}}) = A^{\alpha\beta\lambda\mu} \tilde{\gamma}_{\lambda\mu}(\tilde{\mathbf{u}})$$

$$\begin{cases} \tilde{\gamma}_{11}(\tilde{\mathbf{v}}) = \tilde{\partial}_1 \tilde{v}_1 \\ \tilde{\gamma}_{22}(\tilde{\mathbf{v}}) = \tilde{\partial}_2 \tilde{v}_2 + b_3 \tilde{v}_3 \\ \tilde{\gamma}_{12}(\tilde{\mathbf{v}}) = \tilde{\gamma}_{21}(\tilde{\mathbf{v}}) = \frac{1}{2}(\tilde{\partial}_2 \tilde{v}_1 + \tilde{\partial}_1 \tilde{v}_2) \end{cases}$$

and

$$\tilde{\rho}_{\alpha\beta}(\tilde{\mathbf{v}}) = \tilde{\partial}_{\alpha\beta} \tilde{v}_3 \quad \text{curvature variation tensor}$$

for the triplets $\tilde{\mathbf{v}} = (\tilde{v}_1, \tilde{v}_2, \tilde{v}_3)$.

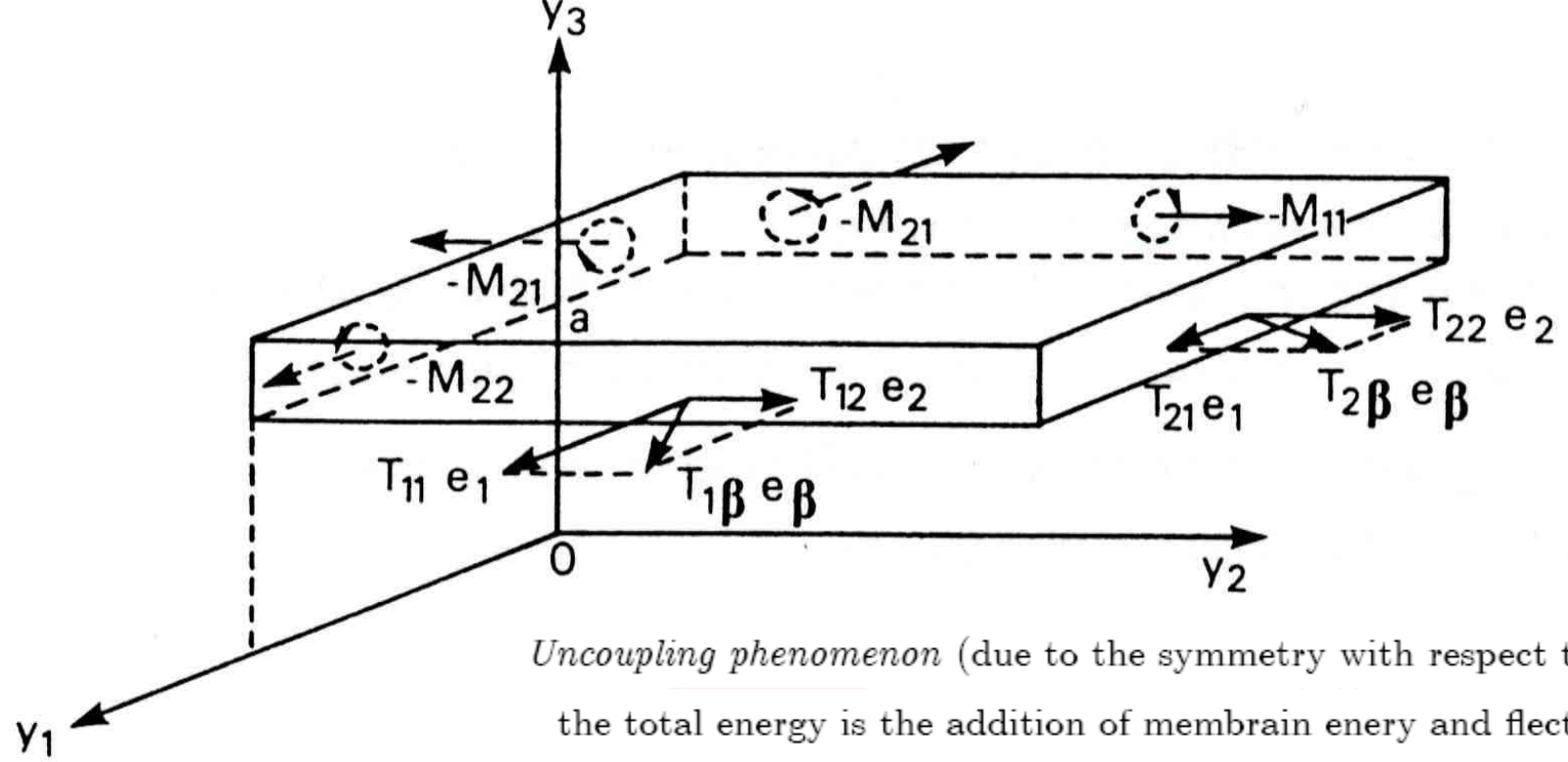

Uncoupling phenomenon (due to the symmetry with respect to $x_3 = 0$):
the total energy is the addition of membran energy and flection energy

The two bilinear forms on V are then defined by:

$$a(\tilde{\mathbf{u}}, \tilde{\mathbf{v}}) = \int_{\Omega_\varepsilon} A^{\alpha\beta\lambda\mu} \tilde{\gamma}_{\alpha\beta}(\tilde{\mathbf{u}}) \tilde{\gamma}_{\lambda\mu}(\tilde{\mathbf{v}}) dx$$

$$b(\tilde{\mathbf{u}}, \tilde{\mathbf{v}}) = \int_{\Omega_\varepsilon} B^{\alpha\beta\lambda\mu} \tilde{\rho}_{\alpha\beta}(\tilde{\mathbf{u}}) \tilde{\rho}_{\lambda\mu}(\tilde{\mathbf{v}}) dx,$$

where the coefficients $A^{\alpha\beta\lambda\mu}$ and $B^{\alpha\beta\lambda\mu}$ satisfy the symmetry and positivity conditions

$$A^{\alpha\beta\lambda\mu} = A^{\beta\alpha\lambda\mu} = A^{\lambda\mu\alpha\beta}$$

$$A^{\alpha\beta\lambda\mu} \theta_{\alpha\beta} \theta_{\lambda\mu} \geq c \theta_{\alpha\beta} \theta_{\alpha\beta} \quad \text{for } \theta_{\alpha\beta} = \theta_{\beta\alpha} \quad \text{with some } c > 0.$$

Remark *It should be noted that the very expression for $\tilde{\rho}_{22}$ in cylindrical shells is*

$$\tilde{\rho}_{22}(\tilde{\mathbf{v}}) = \tilde{\partial}_2^2 \tilde{v}_3 + b \tilde{\partial}_2 \tilde{v}_2$$

but, as we shall see in the sequel the second term is always asymptotically small

As applied forces, we shall give a normal loading depending on ε by the factor ε^3

$$\langle \mathbf{f}, \mathbf{v} \rangle = \varepsilon^3 \int_{\Omega_\varepsilon} F_3(x_1, x_2/\eta) \tilde{v}_3(x_1, x_2) dx,$$

We note that the shape of the profile of the applied loading in x_2 is independent of ε

but applied to the points x_2/η ,

We shall admit in the sequel that

$$F_3 \in L^2(\Omega)$$

where

$$\Omega = (0, l_1) \times (0, l_2).$$

Remark *In the special case when the curvature b vanishes, there is uncoupling between the membrane and flexion problems; the “normal” loading only produces flexion. Moreover, as the width of the shell (the plate, in that case) is $O(\eta)$, the global rigidity is $O(\eta\varepsilon^3)$, of the same order as the total applied force so that, in that case, the solutions (u_3^ε in fact) have a non zero limit.*

We shall see that in our case (i. e., with non zero b) the displacements are very small and only converge to a non zero limit after an appropriate scaling. This amounts to a very high rigidity produced by the curvature as commented at the Introduction.

Problem P_ε . Find $\tilde{\mathbf{u}}^\varepsilon \in \mathbf{V}_\varepsilon$ satisfying $\varepsilon a(\mathbf{u}^\varepsilon, \mathbf{v}) + \varepsilon^3 b(\mathbf{u}^\varepsilon, \mathbf{v}) = \langle \mathbf{f}, \mathbf{v} \rangle \quad \forall \mathbf{v} \in \mathbf{V}_\varepsilon.$

Remark *Since the bilinear forms $a(\mathbf{u}, \mathbf{v})$ and $b(\mathbf{u}, \mathbf{v})$ are symmetric, from well known results we deduce that, in fact, $\tilde{\mathbf{u}}^\varepsilon$ is the unique solution of the minimization problem*

$$\text{Min}_{\mathbf{V}} \tilde{J}_\varepsilon(\mathbf{v})$$

where

$$\tilde{J}_\varepsilon(\mathbf{v}) = \frac{\varepsilon}{2} a(\mathbf{v}, \mathbf{v}) + \frac{\varepsilon^3}{2} b(\mathbf{v}, \mathbf{v}) - \langle \mathbf{f}, \mathbf{v} \rangle.$$

The objective of the rest of the section is to study its asymptotic behavior as $\varepsilon \downarrow 0$.

3. Scaling and a priori estimates in the basic problem.

Let us perform the change of variables :

$$\begin{cases} \mathbf{x} = (x_1, x_2) \Rightarrow \mathbf{y} = (y_1, y_2), \\ y_1 = x_1, \quad y_2 = \eta^{-1}x_2 \end{cases}$$

so, the domain Ω_ε is transformed into Ω and

$$\partial_1 = \tilde{\partial}_1, \quad \partial_2 = \eta \tilde{\partial}_2; \quad \partial_\alpha = \frac{\partial}{\partial y_\alpha}.$$

Moreover, we shall perform the change of unknowns

$$\begin{cases} \tilde{u}_1(\mathbf{x}) = \eta^\theta u_1(\mathbf{y}), \\ \tilde{u}_2(\mathbf{x}) = \eta^{\theta-1} u_2(\mathbf{y}), \\ \tilde{u}_3(\mathbf{x}) = \eta^{\theta-2} b^{-1} u_3(\mathbf{y}), \end{cases}$$

As θ is not defined, the total level of the scaling is not specified, only the mutual ratios of dilatation of the three components are fixed. They are chosen in analogy with layers in parabolic shells. Specifically, the ratio between the components 1 and 2 is fixed in order that the new form of the shear membrane strain \tilde{e}_{12} be formed by two terms of the same order (which, on the other hand, are asymptotically large, forming a constraint for the limit problem). The ratio between the components 2 and 3 is also fixed in such a way that the new form of the membrane strain \tilde{e}_{22} be formed by two terms of the same order.

We then perform the previous change for $\tilde{\mathbf{u}}^\varepsilon$ as well as for $\tilde{\mathbf{v}}$ in P_ε and we have

$$\begin{aligned}\tilde{\gamma}_{11}(\tilde{\mathbf{v}}) &= \eta^\theta \partial_1 v_1 \\ \tilde{\gamma}_{12}(\tilde{\mathbf{v}}) &= \tilde{\gamma}_{21}(\tilde{\mathbf{v}}) = \eta^{\theta-1} \frac{1}{2} (\partial_2 v_1 + \partial_1 v_2), \\ \tilde{\gamma}_{22}(\tilde{\mathbf{v}}) &= \eta^{\theta-2} (\partial_2 v_2 + v_3), \\ \tilde{\rho}_{11}(\tilde{\mathbf{v}}) &= \eta^{\theta-2} b^{-1} \partial_1^2 v_3, \\ \tilde{\rho}_{12}(\tilde{\mathbf{v}}) &= \tilde{\rho}_{21}(\tilde{\mathbf{v}}) = \eta^{\theta-3} b^{-1} \partial_1 \partial_2 v_3, \quad \tilde{\rho}_{22}(\tilde{\mathbf{v}}) = \eta^{\theta-4} b^{-1} \partial_2^2 v_3.\end{aligned}$$

It will prove useful to define

$$\begin{aligned}\gamma_{11}^\varepsilon(\mathbf{v}) &= \partial_1 v_1 \\ \gamma_{12}^\varepsilon(\mathbf{v}) &= \gamma_{21}^\varepsilon(\mathbf{v}) = \eta^{-1} \frac{1}{2} (\partial_2 v_1 + \partial_1 v_2), \\ \gamma_{22}^\varepsilon(\mathbf{v}) &= \eta^{-2} (\partial_2 v_2 + v_3); \\ \rho_{11}^\varepsilon(\mathbf{v}) &= \eta^2 \partial_1^2 v_3, \\ \rho_{12}^\varepsilon(\mathbf{v}) &= \rho_{21}^\varepsilon(\mathbf{v}) = \eta \partial_1 \partial_2 v_3, \\ \rho_{22}^\varepsilon(\tilde{\mathbf{v}}) &= \partial_2^2 v_3.\end{aligned}$$

so that:

$$\begin{aligned}\tilde{\gamma}_{11}(\tilde{\mathbf{v}}) &= \eta^\theta \gamma_{11}^\varepsilon(\mathbf{v}) \\ \tilde{\gamma}_{12}(\tilde{\mathbf{v}}) &= \tilde{\gamma}_{21}(\tilde{\mathbf{v}}) = \eta^\theta \gamma_{12}^\varepsilon(\mathbf{v}) \\ \tilde{\gamma}_{22}(\tilde{\mathbf{v}}) &= \eta^\theta \gamma_{22}^\varepsilon(\mathbf{v}) \\ \tilde{\rho}_{11}(\tilde{\mathbf{v}}) &= \eta^{\theta-4} b^{-1} \rho_{11}^\varepsilon(\mathbf{v}) \\ \tilde{\rho}_{12}(\tilde{\mathbf{v}}) &= \tilde{\rho}_{21}(\tilde{\mathbf{v}}) = \eta^{\theta-4} b^{-1} \rho_{12}^\varepsilon(\mathbf{v}) \quad \tilde{\rho}_{22}(\tilde{\mathbf{v}}) = \eta^{\theta-4} b^{-1} \rho_{22}^\varepsilon(\mathbf{v}).\end{aligned}$$

We recall that the spatial domain is now $\Omega = (0, l_1) \times (0, l_2)$. The space of configuration, after scaling will be denoted by \mathbf{V} . It is the subspace of

$$H^1(\Omega) \times H^1(\Omega) \times H^2(\Omega)$$

formed by the functions satisfying the kinematic boundary conditions

$$0 = u_1 = u_2 = u_3 \text{ on } \{0\} \times [0, l_2].$$

The expression $\varepsilon a(\mathbf{u}^\varepsilon, \mathbf{v}) + \varepsilon^3 b(\mathbf{u}^\varepsilon, \mathbf{v}) = \langle \mathbf{f}, \mathbf{v} \rangle$ then becomes:

$$P \int_{\Omega} A^{\alpha\beta\lambda\mu} \gamma_{\alpha\beta}^\varepsilon(\mathbf{u}^\varepsilon) \gamma_{\lambda\mu}^\varepsilon(\mathbf{v}) dy + Q \int_{\Omega} B^{\alpha\beta\lambda\mu} \rho_{\alpha\beta}^\varepsilon(\mathbf{u}^\varepsilon) \rho_{\lambda\mu}^\varepsilon(\mathbf{v}) dy = R \int_{\Omega} F_3(y_1, y_2) v_3(y_1, y_2) dy,$$

with

$$P = \varepsilon \eta^{2\theta+1}$$

$$Q = \varepsilon^3 \eta^{2\theta-7} b^{-2}$$

we shall determine the $b(\varepsilon)$ and θ as functions of ε and the function $\eta(\varepsilon)$ using the two equations

$$P = Q = R.$$

This gives $b = \varepsilon/\eta^4$ and $\eta^{\theta-2} = \varepsilon$.

b is always small with respect to η^{-1} , and equal to 1 (or rather $0(1)$) in the "typical example" $\eta = \varepsilon^{1/4}$ we have $\theta = 6$.

Once θ is determined, the scaling $\tilde{u}_3(\mathbf{x}) = \eta^{\theta-2}b^{-1}u_3(\mathbf{y})$ is perfectly defined. We then observe that the factor $\eta^{\theta-2}b^{-1}$

takes the form: η^4 which is always small. It means that the scaling of the component u_3^ε is such that, after scaling, it is asymptotically large with respect to the case before scaling. As we shall prove in the sequel, the scaled unknown u_3^ε has a non zero limit; it follows that the initial unknown \tilde{u}_3^ε tends to 0 at the ratio η^4 . We shall come again on this property, which amounts to the rigidification of the plate with respect to the plane case.

Summing up, the problem P_ε becomes after scaling:

Problem Π_ε . Find $\mathbf{u}^\varepsilon \in \mathbf{V}$ satisfying

$$a^\varepsilon(\mathbf{u}^\varepsilon, \mathbf{v}) = \int_{\Omega} F_3(y_1, y_2)v_3(y_1, y_2)dy.$$

$\forall v \in \mathbf{V}$, where

$$a^\varepsilon(\mathbf{u}^\varepsilon, \mathbf{v}) \stackrel{def}{=} \int_{\Omega} A^{\alpha\beta\lambda\mu}\gamma_{\alpha\beta}^\varepsilon(\mathbf{u}^\varepsilon)\gamma_{\lambda\mu}^\varepsilon(\mathbf{v})dy + \int_{\Omega} B^{\alpha\beta\lambda\mu}\rho_{\alpha\beta}^\varepsilon(\mathbf{u}^\varepsilon)\rho_{\lambda\mu}^\varepsilon(\mathbf{v})dy.$$

It should be emphasized that, by virtue of the definitions the coefficients involve various powers of η , running from -4 to $+4$. The terms in η^{-4} to η^{-1} are “penalty terms”, whereas those in η^1 to η^4 are “singular perturbation terms”. Only the terms of order 1 will remain in the limit expression.

Remark \mathbf{u}^ε is the unique solution of the minimization problem

$$\text{Min}_{\mathbf{V}} J_\varepsilon(\mathbf{v})$$

where

$$J_\varepsilon(\mathbf{v}) = \frac{1}{2}a^\varepsilon(\mathbf{v}, \mathbf{v}) - \langle \mathbf{f}, \mathbf{v} \rangle.$$

Let us proceed to the a priori estimates. From the expression of $a^\varepsilon(\mathbf{v}, \mathbf{v})$ with $\mathbf{u}^\varepsilon = \mathbf{v}$,

Lemma *The estimates:*

$$\begin{aligned} \|\partial_1 v_1\|_{L^2(\Omega)}^2 &\leq ca^\varepsilon(\mathbf{v}, \mathbf{v}) \\ \|\eta^{-1} \frac{1}{2} (\partial_2 v_1 + \partial_1 v_2)\|_{L^2(\Omega)}^2 &\leq ca^\varepsilon(\mathbf{v}, \mathbf{v}) \\ \|\eta^{-2} (\partial_2 v_2 + v_3)\|_{L^2(\Omega)}^2 &\leq ca^\varepsilon(\mathbf{v}, \mathbf{v}) \\ \|\partial_2^2 v_3\|_{L^2(\Omega)}^2 &\leq ca^\varepsilon(\mathbf{v}, \mathbf{v}) \\ \|\eta \partial_1 \partial_2 v_3\|_{L^2(\Omega)}^2 &\leq ca^\varepsilon(\mathbf{v}, \mathbf{v}) \\ \|\eta^2 \partial_1^2 v_3\|_{L^2(\Omega)}^2 &\leq ca^\varepsilon(\mathbf{v}, \mathbf{v}) \end{aligned}$$

hold true for a certain $c > 0$ independent of ε and $\mathbf{v} \in \mathbf{V}$.

Now, in order to prove that the functional in the right hand side is bounded independently of ε , we need an estimate on u_3 itself.

Lemma *The estimate:*

$$\|v_3\|_{L^2((0,l_1);H^2(0,l_2))}^2 \leq ca^\varepsilon(\mathbf{v}, \mathbf{v})$$

holds true for a certain $c > 0$ independent of ε and $\mathbf{v} \in \mathbf{V}$.

PROOF. Discarding the factors in η and differentiating we have:

$$\begin{aligned} \|\partial_2^2 v_1 + \partial_2 \partial_1 v_2\|_{L^2((0,l_1);H^{-1}(0,l_2))}^2 &\leq ca^\varepsilon(\mathbf{v}, \mathbf{v}) \\ \|\partial_1 \partial_2 v_2 + \partial_1 v_3\|_{H^{-1}((0,l_1);L^2(0,l_2))}^2 &\leq ca^\varepsilon(\mathbf{v}, \mathbf{v}). \end{aligned}$$

using the fact that v_1 vanishes on $\{0\} \times [0, l_2]$, by using the Poincaré's inequality we obtain:

$$\|v_1\|_{H^1((0, l_1); L^2(0, l_2))}^2 \leq ca^\varepsilon(\mathbf{v}, \mathbf{v})$$

and differentiating,

$$\|\partial_2^2 v_1\|_{H^1((0, l_1); H^{-2}(0, l_2))}^2 \leq ca^\varepsilon(\mathbf{v}, \mathbf{v}).$$

taking the weaker norm, it follows that

$$\|\partial_2 \partial_1 v_2\|_{L^2((0, l_1); H^{-2}(0, l_2))}^2 \leq ca^\varepsilon(\mathbf{v}, \mathbf{v})$$

$$\|\partial_1 v_3\|_{H^{-1}((0, l_1); H^{-2}(0, l_2))}^2 \leq ca^\varepsilon(\mathbf{v}, \mathbf{v})$$

or even (integrating with respect to y_1 on account of the vanishing of the trace on $\{0\} \times [0, l_2]$):

$$\|v_3\|_{L^2((0, l_1); H^{-2}(0, l_2))}^2 \leq ca^\varepsilon(\mathbf{v}, \mathbf{v}).$$

The conclusion follows.

Lemma *The estimate*

$$\left| \int_{\Omega} F_3 v_3 dy \right| \leq ca^\varepsilon(\mathbf{v}, \mathbf{v})^{1/2}$$

holds true for a certain $c > 0$ independent of ε and $\mathbf{v} \in \mathbf{V}$.

Now, taking $\mathbf{v} = \mathbf{u}^\varepsilon$ we get the energy estimate:

Lemma *Let \mathbf{u}^ε be the solution of Π_ε . The estimates*

$$\|\gamma_{\alpha\beta}^\varepsilon(u^\varepsilon)\| \leq C \quad \alpha, \beta = 1, 2 \quad \|\partial_1 u_1^\varepsilon\|_{L^2(\Omega)}^2 \leq C$$

$$\|\eta^{-1} \frac{1}{2} (\partial_2 u_1^\varepsilon + \partial_1 u_2^\varepsilon)\|_{L^2(\Omega)}^2 \leq C \quad \|\eta^{-2} (\partial_2 u_2^\varepsilon + u_3^\varepsilon)\|_{L^2(\Omega)}^2 \leq C$$

$$\|\partial_2^2 u_3^\varepsilon\|_{L^2(\Omega)}^2 \leq C \quad \|\eta \partial_1 \partial_2 u_3^\varepsilon\|_{L^2(\Omega)}^2 \leq C \quad \|\eta^2 \partial_1^2 u_3^\varepsilon\|_{L^2(\Omega)}^2 \leq C$$

hold true for a certain $C > 0$ independent of ε .

We shall need an estimate on u_2^ε itself. We shall obtain it by differentiating with respect to y_2 and integrating in y_1 .

Lemma *Let \mathbf{u}^ε be the solution of Π_ε . The estimates*

$$\|u_1^\varepsilon\|_{H^1((0,l_1);L^2(0,l_2))} \leq C \quad \|u_2^\varepsilon\|_{\tilde{H}_0^1((0,l_1);H^{-1}(0,l_2))} \leq C \quad \|u_3^\varepsilon\|_{L^2((0,l_1);H^2(0,l_2))}^2 \leq C,$$

holds true for a certain $C > 0$ independent of ε , where

$$\tilde{H}_0^1((0,l_1);H^{-1}(0,l_2)) = \{w \in H^1((0,l_1);H^{-1}(0,l_2)) \text{ such that } w(0,\cdot) = 0\}.$$

A first result of convergence is

Lemma *Let \mathbf{u}^ε be the solution of Π_ε . The following convergences (as $\varepsilon \rightarrow 0$) hold true (in the sense of subsequences, the limits being not necessarily unique):*

$$u_1^\varepsilon \rightarrow u_1^* \quad \text{weakly in } \tilde{H}_0^1((0,l_1);L^2(0,l_2)) \quad u_2^\varepsilon \rightarrow u_2^* \quad \text{weakly in } \tilde{H}_0^1((0,l_1);H^{-1}(0,l_2))$$

$$u_3^\varepsilon \rightarrow u_3^* \quad \text{weakly in } L^2((0,l_1);H^2(0,l_2))$$

where $\mathbf{u}^* = (u_1^*, u_2^*, u_3^*)$ are distributions on Ω , belonging to the spaces specified

$$\partial_2 u_1^* + \partial_1 u_2^* = 0$$

$$\partial_2 u_2^* + u_3^* = 0.$$

Finally,

$$\gamma_{\alpha\beta}^\varepsilon(\mathbf{u}^\varepsilon) \rightarrow \gamma_{\alpha\beta}^* \quad \text{weakly in } L^2(\Omega), \quad \alpha, \beta = 1, 2,$$

for some $\gamma_{\alpha\beta}^* \in L^2(\Omega)$.

4. Limit problem and convergence in the basic problem.

Let us define the space \mathbf{G} for the definition of the limit problem:

$$\mathbf{G} = \{\mathbf{v} = (v_1, v_2, v_3) \in \tilde{H}_0^1((0, l_1); L^2(0, l_2)) \times \tilde{H}_0^1((0, l_1); H^{-1}(0, l_2)) \times L^2((0, l_1); H^2(0, l_2)),$$

$$\partial_2 v_1 + \partial_1 v_2 = 0, \quad \partial_2 v_2 + b v_3 = 0\},$$

where we observe that v_1 defines completely v_2 and then v_3 .

Clearly, \mathbf{G} is a Hilbert space with the norm

$$\begin{cases} \|\mathbf{v}\|_{\mathbf{G}}^2 = \|v_1\|_{\tilde{H}_0^1((0, l_1); L^2(0, l_2))}^2 + \|\partial_2^2 v_3\|_{L^2(\Omega)}^2 \\ \simeq \|\partial_1 v_1\|_{L^2(\Omega)}^2 + \|\partial_2^3 v_2\|_{L^2(\Omega)}^2 \end{cases}$$

Remark *A straightforward comparison with the space \mathbf{V} shows that the space \mathbf{G} for the limit problem incorporates the two constraints corresponding to the "penalty terms" in Π_ε whereas the boundary conditions for u_3 , which are concerned with the "singular perturbation terms" in Π_ε are lost.*

It is worthwhile to state an equivalent definition of the space \mathbf{G} where the functions are defined in terms of a scalar "potential ψ ":

Lemma *The space \mathbf{G} may equivalently be defined as the space of the triplets $\mathbf{v} = (v_1, v_2, v_3)$ such that:*

$$v_1 = \partial_1 \psi, \quad v_2 = -\partial_2 \psi, \quad v_3 = -\partial_2^2 \psi.$$

where ψ is an element of

$$\tilde{G} = \tilde{H}_0^2((0, l_1); L^2(0, l_2)) \cap L^2((0, l_1); H^4(0, l_2))$$

where

$$\tilde{H}_0^2((0, l_1); L^2(0, l_2)) = \{\psi \in H^2((0, l_1); L^2(0, l_2)); \psi(0, y_2) = \partial_1 \psi(0, y_2) = 0\}.$$

Remark The introduction of the scalar potential φ seems to be new in the shell literature. Some closed, but different, ideas can be associated with the *stress function* introduced by G.B. Airy (1801-1892)

It should prove useful to prove a lemma on density in \mathbf{G} .

Lemma *The subspace of \mathbf{G} formed by the elements $\mathbf{v} = (v_1, v_2, v_3)$ which are smooth, vanish in a neighborhood of $\{0\} \times [0, l_2]$ and derive from a "potential" ψ is dense in \mathbf{G} .*

We are now defining the limit problem. It involves the numerical coefficient $1/C_{1111}$, and B^{2222} where $C_{\alpha\beta\lambda\mu}$ is the matrix inverse of $A^{\alpha\beta\lambda\mu}$, i. e. the matrix of membrane compliances, and \mathbf{B} is the matrix of flexion rigidities. They are both strictly positive.

$$\tilde{\gamma}_{\lambda\mu}(\tilde{\mathbf{u}}) = C_{\lambda\mu\alpha\beta} \tilde{T}^{\beta\alpha}(\tilde{\mathbf{u}})$$

Problem Π_0 . Find $\mathbf{u} \in \mathbf{G}$ such that

$$\int_{\Omega} \frac{1}{C_{1111}} \partial_1 u_1 \partial_1 v_1 dy + \int_{\Omega} B^{2222} \partial_2^2 u_3 \partial_2^2 v_3 dy = \int_{\Omega} F_3 v_3 dy.$$

$\forall \mathbf{v} \in \mathbf{G}$, or equivalently, in terms of the potential, find $\varphi \in \tilde{G}$ such that

$$\int_{\Omega} \frac{1}{C_{1111}} \partial_1^2 \varphi \partial_1^2 \psi dy + \int_{\Omega} B^{2222} \partial_2^4 \varphi \partial_2^4 \psi dy = - \int_{\Omega} F_3 \partial_2^2 \psi dy,$$

$\forall \psi \in \tilde{G}$.

Obviously, this problem is in the Lax - Milgram framework, as the right hand side is a continuous functional on \mathbf{G} . We then have

Theorem Under the assumption $F_3 \in L^2(\Omega)$, Problem Π_0 has a unique solution.

Our main convergence result is:

Theorem Let \mathbf{u}_ε and \mathbf{u} be the solutions of Π_η and Π_0 respectively. Then, for $\varepsilon \downarrow 0$, we have:

$$\mathbf{u}^\varepsilon \rightarrow \mathbf{u}$$

In other words, the limit \mathbf{u}^* is the solution of the limit problem

The corresponding higher order partial differential equation for φ is obviously

$$\left(\frac{1}{C_{1111}}\partial_1^4 + B^{2222}\partial_2^8\right)\varphi = -\partial_2^2 F_3.$$

parabolic according the theory of linear partial differential equations

Remark *if we define the bilinear form*

$$a^0(\mathbf{u}, \mathbf{v}) \stackrel{def}{=} \int_{\Omega} \frac{1}{C_{1111}} \partial_1 u_1 \partial_1 v_1 dy + \int_{\Omega} B^{2222} \partial_2^2 u_3 \partial_2^2 v_3 dy,$$

then the symmetry of $a^0(\mathbf{u}, \mathbf{v})$ shows that the (unique) solution \mathbf{u} of problem Π_0 can be characterized as the unique element of \mathbf{G} solving the minimization problem

$$Min_{\mathbf{G}} J_0(\mathbf{v})$$

where

$$J_0(\mathbf{v}) = \frac{1}{2} a^0(\mathbf{v}, \mathbf{v}) - \int_{\Omega} F_3 v_3 dy.$$

We can formulate, equivalently, this property in terms of the potential φ

So, the (unique) solution $\varphi \in \tilde{G}$ of problem Π_0 can be characterized as the unique element of \tilde{G} solving the minimization problem

$$Min_{\tilde{G}} \tilde{J}_0(\psi)$$

$$\tilde{J}_0(\psi) = \frac{1}{2C_{1111}} \int_{\Omega} |\partial_1^2 \psi|^2 dy + \frac{B^{2222}}{2} \int_{\Omega} |\partial_2^4 \psi|^2 dy + \int_{\Omega} F_3 \partial_2^2 \psi dy$$

5. The shell has an edge with slight folding ...

In this section we consider a case slightly more complicated than the basic problem, when the section by $y_1 = \text{const.}$ is as sketched in Fig 2.

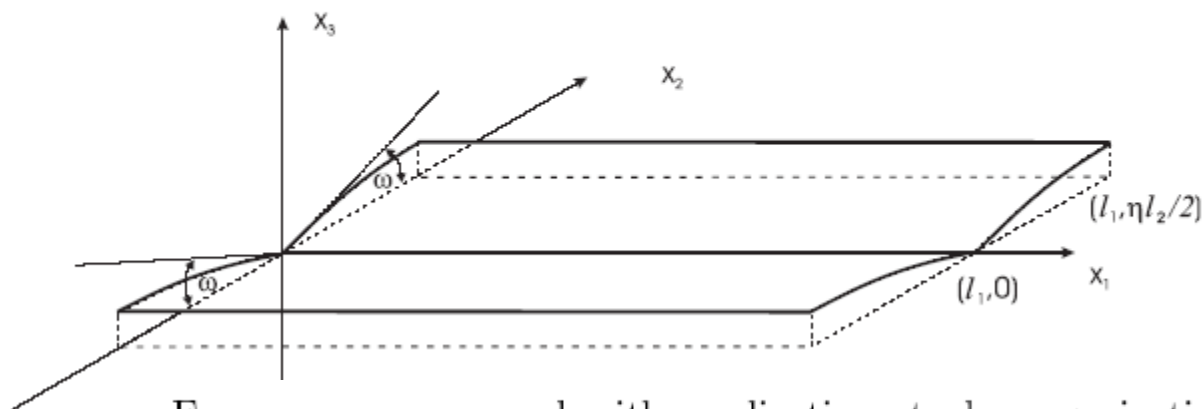

For reasons concerned with applications to homogenization problems tangent plane on $y_2 = -l_2/2$ and $y_2 = l_2/2$ is horizontal. This amounts to saying that the angle of the folding is 2ω , with $\omega = b\eta l_2/2$ (see Fig 2) where b always denote the (constant) curvature. Denoting by \tilde{u}_i^- and \tilde{u}_i^+ the traces on $x_2 = 0$, the continuity of the displacement $\tilde{\mathbf{u}}$ at the folding gives in the projections along x_1 , its normal in the "base plane" and the axis Z (see Fig. 2) respectively:

In order to avoid irrelevant and cumbersome expressions, as ω is small, we shall take $\cos\omega = 1$, $\sin\omega = \omega$. Moreover, we shall see in the sequel that the components u_3 are asymptotically larger than u_2 , and we shall neglect $\omega^2 u_2$ with respect to u_3 . Then we shall consider

$$\begin{cases} \tilde{u}_1^+ = \tilde{u}_1^- \\ -\omega\tilde{u}_3^+ + \tilde{u}_2^+ = \omega\tilde{u}_3^- + \tilde{u}_2^- \\ \tilde{u}_3^+ = \tilde{u}_3^- \end{cases}$$

so that we merely may keep in mind that \tilde{u}_1 and \tilde{u}_3 are continuous across $x_2 = 0$ and

$$\tilde{u}_2^+ - \tilde{u}_2^- = 2\omega\tilde{u}_3.$$

Let us denote

$$\Omega_\varepsilon^+ = (0, l_1) \times (0, \eta l_2/2) \quad \text{and} \quad \Omega_\varepsilon^- = (0, l_1) \times (-\eta l_2/2, 0)$$

and we shall also denote by Ω_ε the union of Ω_ε^+ and Ω_ε^- . The space of configuration will be denoted by \mathbf{V}_ε . It is the subspace of

$$H^1(\Omega_\varepsilon^+) \times H^1(\Omega_\varepsilon^+) \times H^2(\Omega_\varepsilon^+) \times H^1(\Omega_\varepsilon^-) \times H^1(\Omega_\varepsilon^-) \times H^2(\Omega_\varepsilon^-)$$

formed by the functions satisfying the kinematic boundary conditions

$$\begin{aligned} 0 &= \tilde{u}_1^+ = \tilde{u}_2^+ = \tilde{u}_3^+ \quad \text{on } \{0\} \times [0, \eta l_2/2], \\ 0 &= \tilde{u}_1^- = \tilde{u}_2^- = \tilde{u}_3^- \quad \text{on } \{0\} \times [-\eta l_2/2, 0], \end{aligned}$$

and the transmission conditions

The “variational or weak formulation” of the elasticity problem for this structure takes again the form

$$\varepsilon a(\mathbf{u}^\varepsilon, \mathbf{v}) + \varepsilon^3 b(\mathbf{u}^\varepsilon, \mathbf{v}) = \langle \mathbf{f}, \mathbf{v} \rangle$$

with

$$\begin{aligned} a(\tilde{\mathbf{u}}, \tilde{\mathbf{v}}) &= \int_{\Omega_\varepsilon^+} A^{\alpha\beta\lambda\mu} \tilde{\gamma}_{\alpha\beta}(\tilde{\mathbf{u}}^+) \tilde{\gamma}_{\lambda\mu}(\tilde{\mathbf{v}}^+) dx + \int_{\Omega_\varepsilon^-} A^{\alpha\beta\lambda\mu} \tilde{\gamma}_{\alpha\beta}(\tilde{\mathbf{u}}^-) \tilde{\gamma}_{\lambda\mu}(\tilde{\mathbf{v}}^-) dx \\ b(\tilde{\mathbf{u}}, \tilde{\mathbf{v}}) &= \int_{\Omega_\varepsilon^+} B^{\alpha\beta\lambda\mu} \tilde{\rho}_{\alpha\beta}(\tilde{\mathbf{u}}^+) \tilde{\rho}_{\alpha\beta}(\tilde{\mathbf{v}}^+) dx + \int_{\Omega_\varepsilon^-} B^{\alpha\beta\lambda\mu} \tilde{\rho}_{\alpha\beta}(\tilde{\mathbf{u}}^-) \tilde{\rho}_{\alpha\beta}(\tilde{\mathbf{v}}^-) dx, \end{aligned}$$

where we are using the obvious decomposition $\tilde{\mathbf{v}} = (\tilde{\mathbf{v}}^+, \tilde{\mathbf{v}}^-)$ for any element of the energy space \mathbf{V}_ε .

The scaling and other developments are then analogous to those of the "basic problem". The space of configuration after scaling will be denoted by \mathbf{V} . It is the subspace of

$$H^1(\Omega^+) \times H^1(\Omega^+) \times H^2(\Omega^+) \times H^1(\Omega^-) \times H^1(\Omega^-) \times H^2(\Omega^-)$$

formed by the functions satisfying the transmission and kinematic boundary conditions

$$u_2^+ - u_2^- = l_2 u_3$$

and

$$0 = u_1 = u_2 = u_3 \quad \text{on} \quad \{0\} \times [-l_2/2, l_2/2],$$

Theorem *Let \mathbf{u}_ε and \mathbf{u} be the solutions of the above coupled problems respectively. Then, for $\varepsilon \downarrow 0$, we have:*

$$\mathbf{u}^\varepsilon \rightarrow \mathbf{u}$$

with convergence of each component $\mathbf{u}^\varepsilon = (\mathbf{u}^{\varepsilon+}, \mathbf{u}^{\varepsilon-})$

Equivalently, the limit \mathbf{u} can be obtained through its potential $\varphi = (\varphi^+, \varphi^-) \in \tilde{G}$, solution of

$$\begin{aligned} & \int_{\Omega^+} \frac{1}{C_{1111}} \partial_1^2 \varphi^+ \partial_1^2 \psi^+ dy + \int_{\Omega^-} \frac{1}{C_{1111}} \partial_1^2 \varphi^+ \partial_1^2 \psi^+ dy \\ & + \int_{\Omega^+} B^{2222} \partial_2^4 \varphi^+ \partial_2^4 \psi^+ dy + \int_{\Omega^-} B^{2222} \partial_2^4 \varphi^- \partial_2^4 \psi^- dy \\ & = - \int_{\Omega^+} F_3 \partial_2^2 \psi^+ dy - \int_{\Omega^-} F_3 \partial_2^2 \psi^- dy, \end{aligned}$$

$$\forall \psi = (\psi^+, \psi^-) \in \tilde{G}.$$

We consider now the case in which the shell is $2\eta l_2$ -periodic with respect the section by $x_1 = \text{const.}$ projected on the band $(0, l_1) \times (-\infty, +\infty)$ and having a slight folding at any section of the form $(0, l_1) \times \{k\eta l_2\}$ with $k \in \mathbb{Z}$, as sketched in Fig 3.

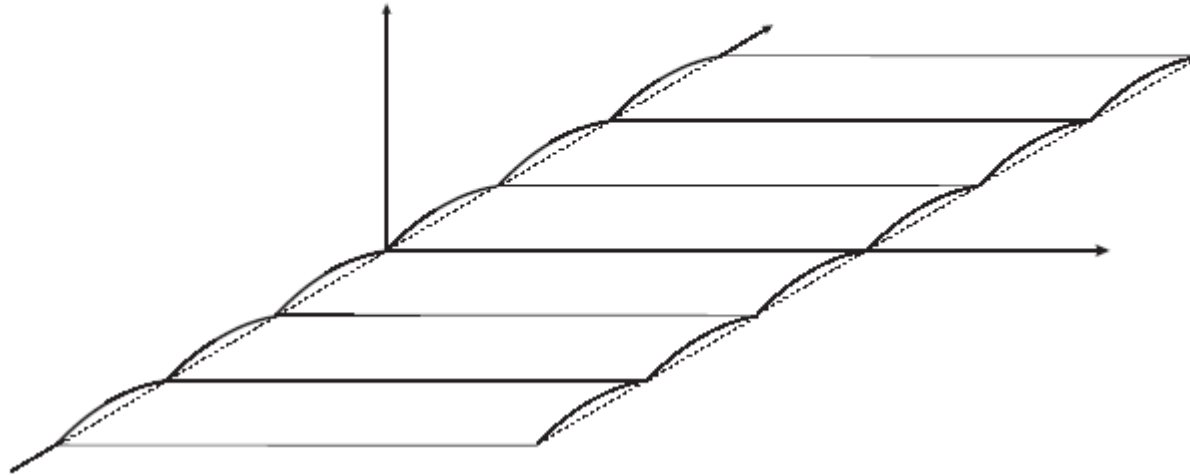

We can consider as "unit shell" the shell defined through the rectangle $(0, l_1) \times (-\eta l_2, +\eta l_2)$, clamped along the "small sides" at $\{0\} \times [-\eta l_2, \eta l_2]$, which implies again kinematic boundary conditions similar to those indicated

We then consider periodic loadings and search for periodic solutions.

The convergence arguments follows as in previous Subsections with easy modifications.

Remark. Many other results (global properties, the obstacle problem, ...), work in progress (homogenization, hyperbolic surfaces, ...). Many open problems.

Thanks for your attention

